

# EYELA

ProcessStation PPS is personal and economic system that can do the different liquid phase handling and research promptly and efficiently.

**New**

**It is ideal for development of drug, medicine catalyst and fine chemical materials.**

---

PPS-1511•2511•3511•5511

- Wide temp. control range of -28°C~160°C
- 5 independent temperature control
- Ramp temperature control
- Wide synthesis scale 0.5mL - 60mL
- Heating, cooling, reflux and stirring functions



TOKYO RIKAKIKAI CO., LTD.

## PPS series have been developed to improve the efficiency of synthesis process.

Since five test tubes can be set, it is ideal for new reaction and development, verification experiment, experiment for optimization and synthesizing simple or new catalyst, and also for large volume intermediate synthesis.

Five different temperature can be set for five different tubes, which can save the time and perform efficient synthesis.

Reflux, gas flushing, heating, cooling and stirring functions are equipped as standard.

As synthesis scale can be changed, the setting for experiment can be easily changed as well.



PPS-3511

### Product Line

	<p><b>0.5~60mL 1-20 Vessels</b></p> <p>PPS-5511</p> <ul style="list-style-type: none"> <li>Test tube 1~5(Max.20)</li> <li>Scale 0.5~60mL (Variable)</li> <li>Temp.range-23~160°C (50~60mL; ~130°C)</li> </ul>
	<p><b>1~4mL</b></p> <p>PPS-1511</p> <ul style="list-style-type: none"> <li>Test tube 1~5</li> <li>Scale 1~4mL</li> <li>Temp. range-23~160°C</li> </ul>
	<p><b>10~30mL</b></p> <p>PPS-2511</p> <ul style="list-style-type: none"> <li>Test tube 1~5</li> <li>Scale 10~30mL</li> <li>Temp. range-27~160°C</li> </ul>
	<p><b>50~60mL</b></p> <p>PPS-3511</p> <ul style="list-style-type: none"> <li>Test tube 1~5</li> <li>Scale 50~60mL</li> <li>Temp. range-28~130°C</li> </ul>

### Features of PPS Series (Common to all models)



#### High-efficiency independent temperature controller

5 temperature sensors and temperature controllers are equipped for each five heating blocks.

Range of temperature setting is from -28°C to 160°C. Reflux, heating and cooling can be controlled simultaneously (Pat.) Accurate temperature control can be performed even around room temperature ( $\pm 0.5^\circ\text{C}$ ) and temperature fall can be executed smoothly as well. After having reaction in high temperature, the block can be cooled speedily if the temperature control is stopped, which prevents over-reaction.

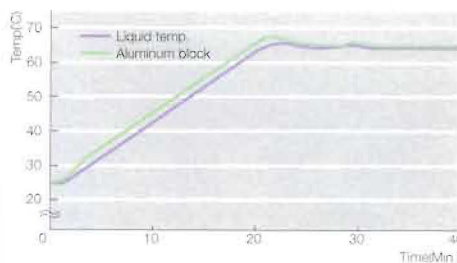

#### Ramp temperature control

Temperature can be raised or fallen at constant speed to preset temperature.

\*Temperature raise control: slowly raise temperature to the point where reaction starts

\*Temperature fall control: can slowly cool down due to crystallization

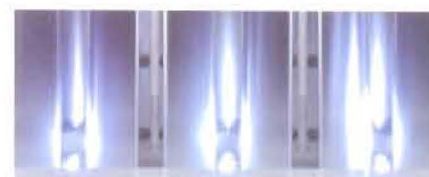

#### Strong stirring & LED light

Ferromagnetic stirrer is equipped for each test tube which performs strong and stable vortex stirring.

Irregular suspension reaction using poorly-soluble powder sample and solid catalyst, crystallization reaction, high-viscosity solvent (ethylene glycol and etc.) can be stirred. The progress of reaction caused in test tube (color, condition, stirring force and etc.) can be observed through the window on the front surface with LED light.



#### Safety features

In case that solvent spills from broken tube, Teflon tray receives it to protect the device. Double chamber prevents dew condensation on aluminum block, and also prevents the splash of broken tube. With various over-heat protector, maximum temperature of each aluminum block can be set from 60°C to 200°C. Since heater circuit is protected by setting temperature, safety temperature can be set depending on solvent and operating temperature.



## PPS-5511

PPS-5511 with wide variety of reaction vessels and wide synthesis scale (0.5~60mL) offers wide range of systems according to customer needs.

### PPS-5511 Features



PPS-5511



#### Removable reflux adaptor

Since the reflux adaptor which touches the cooled reflux block, cools down the top of reaction tube, the reaction solvent vapor can be refluxed sufficiently.



#### Synthesis scale can be changed.

By using test tube adaptors, it is possible to change the size and number of reaction vessels. Synthesis scale from 0.5mL to 60mL is feasible. Up to 20 reaction tubes can be placed in the system.



#### Dosing sample

A branched reaction vessel and 3-way cock make it possible to inject reagent in inactive condition or let it drip through a funnel, ideal for heat generating solvents.

### PPS-1511•2511•3511 Features



#### Reflux

Reflux block that contacts test tube is equipped. Since reflux block, which is cooled down by low temperature circulator, can cool off the top of the tube, reaction solvent vapor is refluxed sufficiently.

Cooling cartridge can be inserted from either side of the device.



#### Independent gas flushing

Switching valve for vacuuming line and inert gas line is equipped in gas infusing line of Teflon cap on the top of the test tube. By using this valve, test tube can be deoxidized and dehydrated easily and atmosphere can be flushed by inert gas. With opening the top of the tube a little bit, reaction under gas flow can be implemented.



#### Sample can be added in various ways.

Interchangeable joint (φ15/25) is equipped with the product. With syringe, sample can be added through septum, and also pipetting can be executed under inactive gas current. Interchangeable joint can accommodate your own glassware. By using dripping funnel, dropping experiment can be implemented (even under inactive gas current).

#### Component PPS-1511



#### Component PPS-2511



#### Component PPS-3511



#### Scale up or down of the product is possible.

Temperature control part and stirring part are common to 3 models.

By changing other parts, scale up or down of the product is possible.

# Parts for Personal Organic Synthesizers

## PPS-5511 Parts

### Drip proof cover

Part name	Type	Catalog. No
Drip proof cover (ø12x4 positions)	-	217610
Drip proof cover (ø13)	-	217620
Drip proof cover (ø13x3 positions)	-	217630
Drip proof cover (ø15)	-	217640
Drip proof cover (ø15x3 positions)	-	217650
Drip proof cover (ø16)	-	217660
Drip proof cover (ø16.5)	-	217670
Drip proof cover (ø18)	-	217680
Drip proof cover (ø20)	-	217690
Drip proof cover (ø21)	-	217700
Drip proof cover (ø24)	-	217710
Drip proof cover (ø25)	-	217720
Drip proof cover (ø30)	-	217730
Drip proof cover (ø34)	-	217740
Drip proof cover (ø35)	-	217750

### Drip proof cover

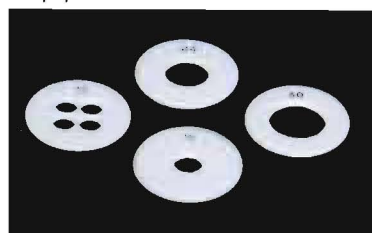

Cover to prevent dew in the aluminum block necessary when using the cooling cartridge.

### Reflux adapter

Part name	Type	Catalog. No
Reflux adapter (ø12x4 positions)	-	217320
Reflux adapter (ø13)	-	217330
Reflux adapter (ø13x3 positions)	-	217340
Reflux adapter (ø15)	-	217350
Reflux adapter (ø15x3 positions)	-	217360
Reflux adapter (ø16)	-	217370
Reflux adapter (ø16.5)	-	217380
Reflux adapter (ø18)	-	217390
Reflux adapter (ø20)	-	217400
Reflux adapter (ø21)	-	217410
Reflux adapter (ø24)	-	217420
Reflux adapter (ø25)	-	217430

### Reflux adapter



Since the reflux adapter cools down the top of the reaction tubes, the reaction solvent vapor can be refluxed effectively.

### Test tube adapter

Part name	Type	Catalog. No
Test tube adapter (ø12 4 positions)	-	217080
Test tube adapter (ø13)	-	212810
Test tube adapter (ø13x3 positions)	-	217090
Test tube adapter (ø15)	-	212820
Test tube adapter (ø15x3 positions)	-	217100
Test tube adapter (ø16)	-	212830
Test tube adapter (ø16.5)	-	212840
Test tube adapter (ø18)	-	212850
Test tube adapter (ø20)	-	212860
Test tube adapter (ø21)	-	212870
Test tube adapter (ø24)	-	212880
Test tube adapter (ø25)	-	212890
Test tube adapter (ø30)	-	212900
Test tube adapter (ø30) for pressure resistant vessel	-	218550
Test tube adapter (ø34) for PPS-5510 only	-	217110

### Test tube adapter



By using a test tube adapter, the size and number of reaction vessels can be changed, to one, three or four per position.

The system can be made fit for up to 20 reaction tubes.

### Septa

Part name	Type	Catalog. No
① Suba seal (silicone rubber, for GL14, 10pcs)	-	212700
② Septum (natural rubber, for 14, 10pcs)	-	218420
③ septum (silicone rubber, for 14, 10pcs)	-	218410
septum (natural rubber, for 15, 10pcs)	-	218430
septum (silicone rubber, for 15, 10pcs)	-	195710

### Stirring bars

Part name	Type	Catalog. No
④ PTFE Magnetic stirring bar (disk shape D9x6H) used for D12, 10pcs	-	182100
⑤ PTFE Magnetic stirring bar (cross shape D10x5H) used for D13-D18, 10pcs	-	191840
⑥ PTFE Magnetic stirring bar (football shape D6x15L) used for D24, 5pcs	-	200280
⑦ PTFE Magnetic stirring bar (football shape D10x20L) used for D0 and 34, 5pcs	-	200290
⑧ PTFE Magnetic stirring bar (football shape D10x25L) used for D34, 5pcs	-	200300
⑨ Powerful magnetic stirring bar (oval shape) D24-D30, 1pce	-	213110
⑩ Powerful magnetic stirring (for viscous liquids), use for D24-D30, 1pce	-	213120
⑪ Glass stirring bar (Thin cylinder shape, D5x12L) for high temp, used for D18-30, 4pcs	-	218330
⑫ Glass stirring bar (Thin cylinder shape, D9.5x12.7L) for high temp, used for D18-30, 1pcs	-	218340

### Septem, Stirrig bar

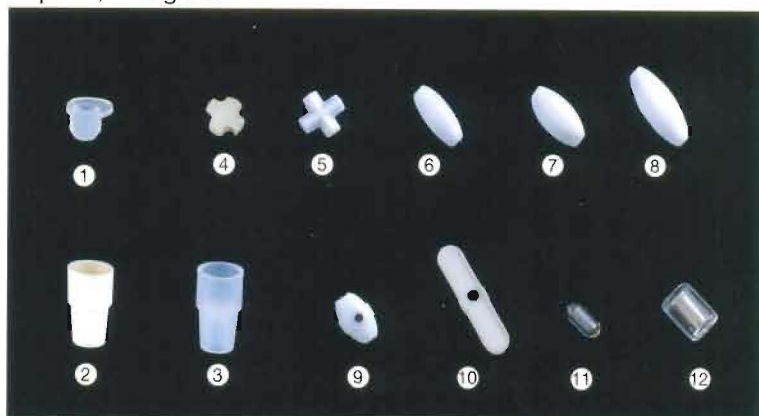



### Reactor glass tube

Part name	Type	Catalog. No
① Standard reaction vessel (ø18 NS14/23)	-	217120
② Standard reaction vessel (ø24 NS14/23)	-	217130
③ Branched reaction vessel (ø18 NS14/23, GL14)	-	217140
④ Branched reaction vessel (ø24 NS14/23, GL14)	-	217150
⑤ Branched reaction vessel (ø30 NS14/23, GL14)	-	212760
⑥ Branched reaction vessel (ø34 NS14/23, GL14)	-	217160
⑦ Sealing reaction vessel (ø16)	-	217170
⑧ Sealing reaction vessel (ø24)	-	217180
⑨ ø30 Stainless pressure resistant vessel (HIP-30)	-	218290
⑩ On head part (with pressure gauge) HIP-HEAD	-	218320

### Condenser, connection hose

Part name	Type	Catalog.
⑪ Dimroth condenser NS14/23, GL14	-	No
⑫ Liebig condenser L100NS14/23, GL14	-	212780
Silicone-hose (used for manifold 5m)	-	212720
Cooling insulation hose set (silicone ø91m, 2pcs) CT-1S	-	212790
Cooling insulation hose set (silicone hose ø92m, 2pcs) CT-2S	-	194050

### NS14/23 related parts

Part name	Type	Catalog. No
⑬ Three-way cock for dosing sample, with solid glass plug	-	217190
⑭ Dean-Stark trap for PPW•CCX type	-	212770
⑮ StopperNS14/23 with hexagonal plate (10pcs)	-	217290
⑯ DIN-Screwthread with NSCone (10pcs)	-	217220
⑰ Adapter with Ground joint, upper TS 15/25 lower cone NS14/23	-	217310
⑱ Dropping funnel 25mL NS14/23	-	217210
⑲ "Keck" Conical Joint Clip type NS14, NS15 metal (10pcs)	-	217300

### GL14 related parts

Part name	Type	Catalog. No
⑳ Screw-Cap with opening for screwthread tubes GL14(10 pcs)	-	217230
㉑ Screw-Cap for screwthread tubes GL14 with PTFE (10 pcs)	-	217240
㉒ Plastic Hose Connection, straight (10 pcs)	-	217250
㉓ Plastic Hose Connection, bent (10 pcs)	-	217260
㉔ Silicone Rubber Seals, Septa (25 pcs)	-	217280
㉕ Silicone Rubber Sealings with Bore	-	217270

### PPS-1511•2511•3511 parts

Part name	Type	Catalog. No
Cross-shaped Stirring bar for ø15 (10pcs)	ST-1X	191840
Cross-shaped Stirring bar for ø30 (10pcs)	ST-2X	191850
Cross-shaped Stirring bar for ø35 (10pcs)	ST-3X	212680
Three-way cock (10pcs)	QK-3P	191920
Cooling insulation hose (1mx2pcs)	CT-1S	194050
Cooling insulation hose (2mx2pcs)	CT-2S	201830
ø15test tube (with rim) (50pcs)	-	195670
ø30test tube (with rim) (25pcs)	-	195690
ø35test tube (with rim) (10pcs)	-	212690
Perfluoro O-ring for PPS-15TC	-	195760
Perfluoro O-ring for PPS-25TC	-	195770
Perfluoro O-ring for PPS-35TC	-	213070
Screw ring for Teflon cap ø15 (5pcs)	-	195640
Screw ring for Teflon cap ø30 (5pcs)	-	195650
Screw ring for Teflon cap ø35 (5pcs)	-	213100
Teflon O-ring for PPS-15TC (10pcs)	-	195780
Teflon O-ring for PPS-25TC (10pcs)	-	195790
Teflon O-ring for PPS-35TC (10pcs)	-	213080
Two-way cock for Teflon cap (5pcs)	-	195700
Gas piping set (PPS type teflon cap)	-	213090
PPS type ø15 Cap part (without Screw cap, with O-ring)	-	195620
PPS type ø30 Cap part (without Screw cap, with O-ring)	-	195630

### Reactor tube, condenser, hose, NS14/23•GL14 related parts

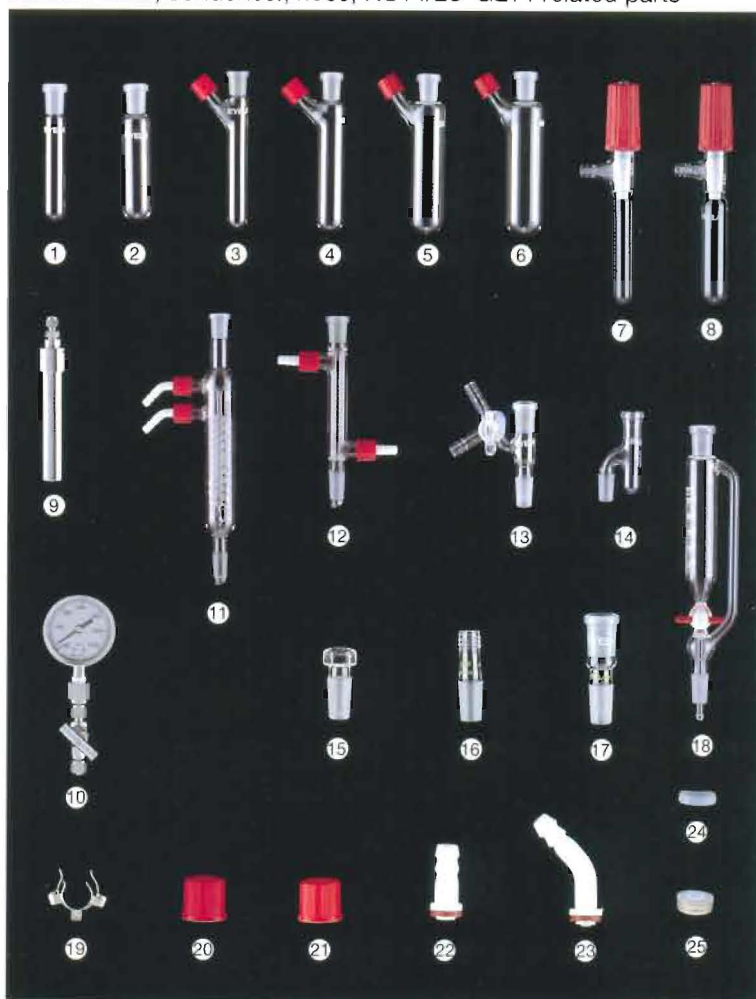

### PPS-1511/2511/3511 Teflon Cap



# PPS-5511 Optional Parts

Adaptability Table

Test tube adaptor			Reflux adaptor	Dew prot. cover	Condenser	Reaction vessel			
OD (o)	Number	Capacity (mL)	Adaptable	OD (ø12-35)	Adaptability	Standard	Branched	Sealed	On-head
12	4	1.2	○	○	X				
13	3	2	○	○	X				
13	1		○	○	X				
15	3	4	○	○	X				
15	1		○	○	X				
16	1	4	○	○	X			○	
		6		○	X				
16.5	1	6	○	○	X				
18	1	7	○	○	○	○	○		
20	1	10	○	○					
21	1	10	○	○					
24	1	10	○	○				○	
24	1	12.5	○	○	○		○		
25	1	14	○	○		○			
30*	1	14	X	○					○
30	1	30	X	○	○		○		
34	1	60	X	○	○		○		
35(no adaptor)		60	X	○					

\* ø30 adaptor for pressure vessel

## Various reaction vessels can be combined depending on your purpose.





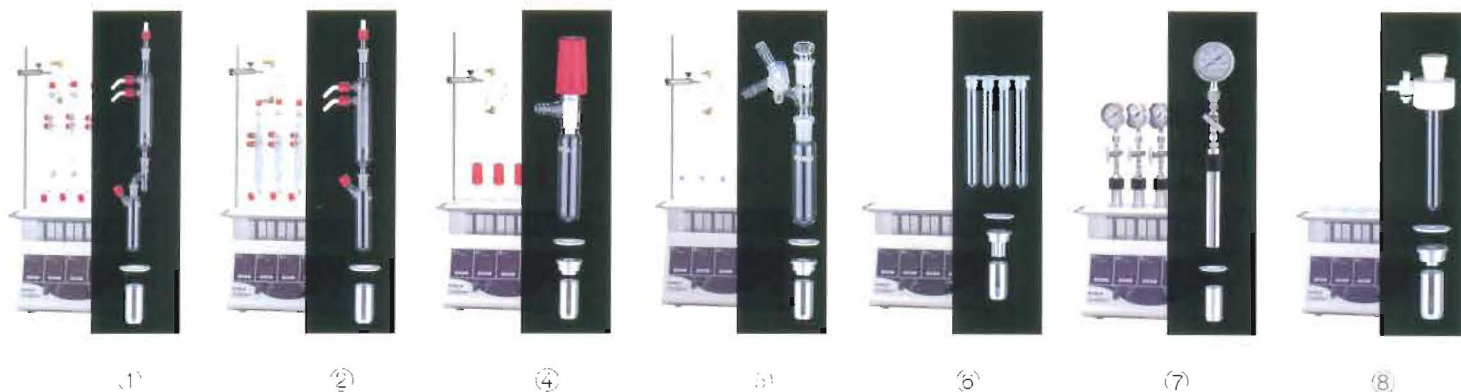





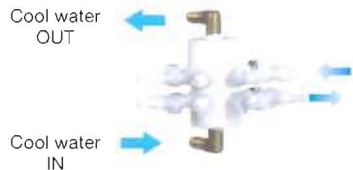



Various types of reaction vessels can expand your possibilities of organic synthesis experiment. The following is our 10 recommended systems.

- ① Polycondensation experiment can be implemented while removing water.
- ② Reaction solvent vapor is condensed and refluxed absolutely.
- ③ Reaction temperature can be monitored.
- ④ By conducting freezing degassing, deoxidization can be implemented completely.
- ⑤ Anhydrous and anoxic reaction can be implemented.
- ⑥ Parallel screening and evaluation of reactions for 20 tubes.
- ⑦ Catalyst reaction can be implemented.
- ⑧ Handy Teflon two-way stopcock.
- ⑨ Concentration can be performed just after the synthesis.
- ⑩ Impeller stirring can be performed.





Various types of reaction tubes and reflux or non-reflux can be selected.

<p>Manifold</p>	<p>Manifold branches off the cool water inlet /out-let, or purge gas, or inactive gas into max. five directions. Manifold has two divergent pathways both on the top and the bottom, so it can be used for branching off the cool water inlet /outlet into five dimroth, and also for branching off vacuum line (10-25hPa) or inactive gas into five 3-way stopcoks.</p>		<p>Cool water manifold</p> 	<p>Gas manifold</p> 				
<p>Various reaction tubes</p>	<p>Branched reaction tube (ø18•24 •30•34)</p> 	<p>Three-cock for adding sample (Schlenk test tube) + standard reaction tube (ø18•24)</p> 	<p>Sealing reaction tube (ø16•24)</p> 	<p>Teflon cap + ø15 test tube (with lip)</p> 	<p>ø12 test tube</p> 	<p>ø30 pressure-resistant vessel + pressure-resistant tube with valve</p> 	<p>Dymroth condenser + Branched reaction tube (ø18•24•30•34)</p> 	<p>Dymroth condenser + Dean-stark trap + Branched reaction tube (ø18•24•30•34)</p> 
<p>Drip-proof cover (ø12-35)</p>								
<p>Reflux adapter (ø12-35)</p>								
<p>Test tube adapter (ø12-35)</p>								
<p>PPS-5511</p>								

# Specifications

Product name	Personal Organic Synthesizer											
	PPS-5511			PPS-1511			PPS-2511			PPS-3511		
Model name	PPS-5511			PPS-1511			PPS-2511			PPS-3511		
Product No.	226490	226499	226498	226460	226469	226468	226470	226479	226478	226480	226489	226488
Voltage	100V	115V	220V	100V	115V	220V	100V	115V	220V	100V	115V	220V
Test tube	1-5pcs (Max.20)			1-4mL			1-5pcs			50-60mL		
Synthesis scale	0.5-60mL(Variable)			1-4mL			10-30mL			50-60mL		
Stirring system	Ferromagnetic stirrer											
Temperature control range	-23-160°C (5x independent control) (50-60mL:-130°C)						-27-160°C (5x ind. control)			-28-130°C (5x ind. control)		
Accuracy of temp. control	±0.5°C											
Rotation speed range	100-2000rpm (Water 1mL) 100-1100rpm (Water 60mL)			100-1600rpm (Water 4mL)			100-1300rpm (Water 30mL)			100-1100rpm (Water 60mL)		
Setting temperature, display	Sheet key input, digital display (-40.0-160.0°C)											
Setting stirring, display	Volume setting, digital display (20-2000rpm)											
Gas flushing	Vacuuming+Infusing inactive gas											
Reflux	High-efficiency reflux											
Adding sample	Pipetting, syringe, dripping funnel (with interchangeable joint).											
Observing reaction	Through the glass on aluminum block (with LED light)											
Safety features	Double chamber, dew receiving tray, variable overheat protector (x5), Low liquid level thermo protector, Temp. controller self diagnosis function											
Material of liquid contact part	Glass, Teflon, Pelture											
Ambient temperature range	5 to 35°C						5 to 35°C					
Dimensions (mm)	465Wx335Dx390H			465Wx335Dx390H			465Wx335Dx440H			465Wx335Dx450H		
Net weight	23kg			25kg			27kg			28kg		
Input power	650VA											

## Standard Accessories for PPS-5511

Manifold	Pole (x1), Arbor (x1), Pole fixer (x1), Silicon hose (x1)
Temp.cont. & stirrer	Fuse (x1), Ground adaptor (x1), CE adaptor (x1)

## Standard Accessories for PPS-1511•2511•3511

Teflon cap	Septum (x5), 3-way cock (x2), Piping set (1 set)
Aluminum block	Test tube (x10), Stirring bar (x5)
Temp.cont. & stirrer	Fuse (x1), Ground adaptor (x1), CE adaptor (x1)

## PPS Series Dimensions (mm)

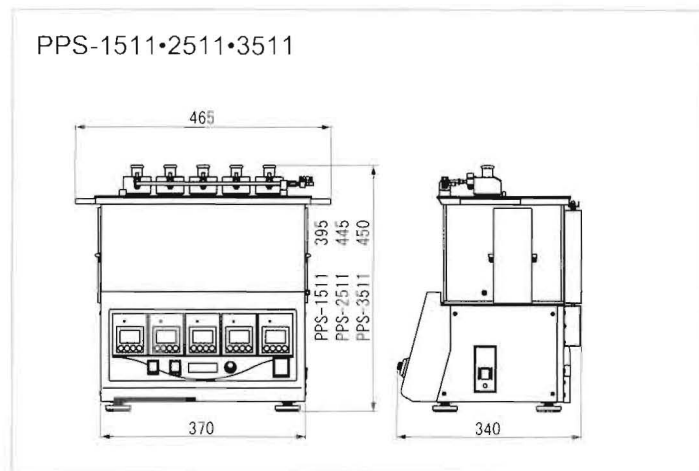
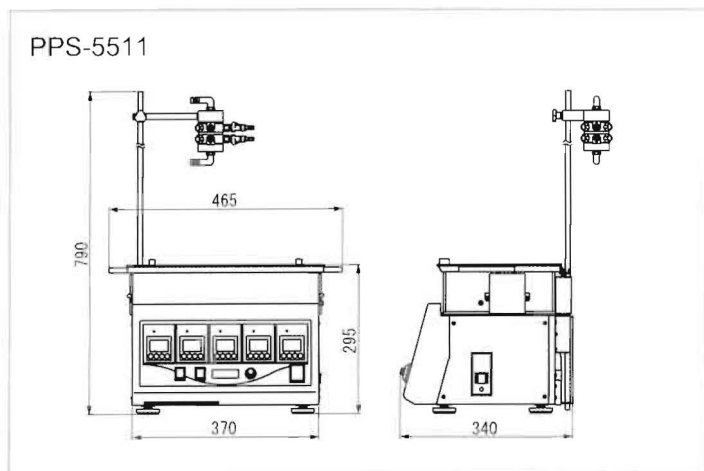

**EYELA**

<http://eyelaworld.com>

TOKYO RIKAKIKAI CO., LTD.  
 TN Koishikawa Bldg.,  
 1-15-17 Koishikawa, Bunkyo-ku  
 Tokyo 112-0002 JAPAN  
 TEL: +81-3-6757-3378  
 FAX: +81-3-3868-6571

Eyela Singapore Pte. Ltd.  
 51 Anson Rd. 07-59  
 Anson Center, Singapore  
 079904  
 TEL: 65-6225-1306  
 FAX: 65-6225-1841  
 eyelasingapore@singnet.com.sg

Eyela Shanghai  
 j-he@eyela.co.jp  
 Eyela Beijing  
 Eyela Guangzhou  
 Eyela USA  
 info@eyelausa.com